



# Sky Writer

See Skymasters on the web at [www.geocities.com/~skymasters](http://www.geocities.com/~skymasters)

## President's Message

Hello all,  
I really like Hamburgers. (Oh goodness, What's he talking about now?) I eat a hamburger at least once a week. But, I've got to be honest, I don't just like hamburger, I like the whole hamburger package. For instance; if I go to a barbecue and the "chef" puts a hamburger on my plate, and nothing else, I don't really enjoy it. To really enjoy it I need a bun, Ketchup, Mayo, Lettuce, maybe a pickle, chips or fries, and an ice cold Pepsi. (No Coke, Pepsi) So, I like all the added items with the burger, not just the burger. I also don't like to eat just ketchup and Mayo, (miracle whip, I won't go there), without the hamburger patty. I need the whole hamburger experience. Otherwise it's boring and I might as well eat a hot dog. (Another story). SO WHAT ROSS? What the heck are you talking about? [It's really about airplanes] (Isn't everything?) {-}

I really enjoy flying my airplane, but I can do that at home. I don't need to come to the Skymasters field to fly my plane. I come for the whole Skymasters package. The Skymaster experience; if you will. Flying my plane is like the hamburger patty, It's

OK, maybe even the meat of flying, but not always enough. I need condiments. (That's the stuff you put on a hamburger Joshua). I enjoy just being at the field. The people who are there. Watching others fly is part, and seeing the different planes is part. Seeing the electrics, the Helis and the slow "park" flyers. The point is I try to enjoy all the parts of the club. At times I don't like pickles on my burger. Same with flying. Sometimes I love to see the helis or slow park fliers fly. I like to buzz around them or fly above them. Then other times I would rather not have to be aware where they are so I don't smash them into little pieces on a low full throttle pass. Even then, I am still glad we are all out there enjoying the field. I try to be aware of all the different flying machines and flying styles because if not, if they didn't come out it would be like just hamburger patty. So, if you see new people or visitors feel free to say hi and tell them a little about our hobby and club. Welcome the Helicopters and slow fliers to fly. (They still need to fly in the pattern, but sometimes their pattern is much smaller). If students are flying with an instructor, they may get "slightly" out of the pattern, if you can help remind them

to fly in the pattern in a friendly manner, please do so.  
So why the hamburger, well a quick reminder that on Wednesdays we could use some hamburgers. We have plenty of chips and hot dogs. So, for a while please don't bring chips and hot dogs. But, do bring yourself, and what ever you like to fly. We always need more condiments.

This month's safety tip: If you are flying a gas powered airplane you need to bring a fire extinguisher with you. I have seen them used. We have one in the flight box, but this is a spare and one for the field. You need to have a dedicated one for your gas airplane.

Note to students: If an instructor is at the field and tells you he shouldn't fly you because he hasn't had enough sleep or because he has headache, you probably don't want him to fly you. It's not worth it to risk your plane, or people's safety. So, I hope to see you out there.

Until then, keep it in the air and in front of the flight line.

Ross



Academy of Model Aeronautics

Chartered Club #970

## 2001 Club Officers

|            |               |                     |            |       |              |
|------------|---------------|---------------------|------------|-------|--------------|
| President: | Ross Hardy    | 3385 W. Sutton Rd,  | Lapeer     | 48446 | 810-797-4917 |
| Vice Pres: | Mark Smith    | 1955 Hopefield      | Lake Orion | 48359 | 248-391-5970 |
| Secretary: | Gary Weaks    | 2512 Red Fox Trail  | Troy       | 48098 | 248-540-8358 |
| Treasurer: | Bob Donohue   | 260 Four Seasons Dr | Lake Orion | 48360 | 248-391-1385 |
| Editor:    | Greg Cardillo | 2086 Cedar Key Ct,  | Lake Orion | 48360 | 248-391-6803 |

Articles must be received by the 20th for next issue.  
Articles may be reproduced from Skywriter.

# Skymasters Events

*Saturday, Aug 4 - 12:00 Noon*

*Skymasters Meeting –Scripps Road Field*

Summer meetings are short – bring a plane and come fly!

*Wednesday Aug 8 - 6:00 PM*

*Annual Fish Fry –Scripps Road Field*

Collection taken up by Bob or Donna Burns to purchase the fish and supplies for the 5 Th. ANNUAL FISH FRY.

Last day for collection the money will be Aug 1st.

As always bring a dish to pass and your own (nonalcoholic) beverage. For more information contact Bob or Donna  
Phone 248-628-4666 or email Old Buzzare@aol.com

*Saturday, Aug 11 - 10:00 AM*

*Multi Engine / Multi Wing –Scripps Road Field*

More than one engine and/or more than one wing to fly in this event... Biplanes, triplanes, and multi-engine planes.

*Sunday, August 19 - 10:00 AM*

*Corn Roast –Scripps Road Field*

Our annual Corn Roast... All the corn you can eat plus whatever food our President chooses. All food drink provided by club for our members, their families, and the neighbors of our field. Our annual Top Gun competition is held as part of this event.

*Saturday/Sunday, September 8-9 - 9:30 AM*

*Midwest Regional Float Fly –Island Lake State Parl*

Our biggest event of the year— over 100 planes the last several years. We need lots of help for this one to run smoothly... Contact Carl Long if you can help!!

## S

Wednesdays throughout the summer are designated as 'Student Night'. It is a day of flying – weather permitting – and eating regardless of weather. Some more details:

**Flying:** Students have priority for flying. Other pilots may fly if pads are free – but please be aware of students that may be waiting. Flying starts as early as 10AM with the day shift - weather permitting. Flying goes till 8PM – with the second shift joining in when we get out of work... We always have instructors at the field to help out – and many others helping with plane inspections and making sure planes are ready to fly. It can be busy – you may not get as many flights as you might other days, but it is a great way to meet instructors and make arrangements for other days.

**Eating:** Regardless of weather, we eat at about 6PM. Dinner is provided by the participants – it is not funded by the club... Here is what we ask of you if you are going to participate in our potluck dinners:

- Bring enough meat (or other) for the grill for at least you and your family.
- Bring a dish to pass – enough for others to share. Don't have time? Many supermarkets have ready-to-eat items... Salads, fruit, rice dishes, potato dishes are all good ideas. We usually have a good supply of desserts. **Note: We have a several week supply of Hot Dogs and various Chips – please bring other items...**
- As an alternative to a dish to pass – we also post a list of staple items needed on a board near the grill... If you see an item listed you would like to bring, turn it over on the board – and bring that next week instead of a dish to pass...
- Bring your own (non-alcoholic) beverage.

The more variety people bring, the better the selection for dinner. Thanks to all participants!

## From

Welcome to the July/August 2001 issue of Skywriter! Hey – July and August??? What happened?? Well – life got a bit hectic – an unexpected trip for 10 days right in the publishing window didn't help – so to get back on track, this issue is a combined July/August issue...

This is a busy time of year for Skymasters – we have several events coming – see list above. Two I would like to highlight:

Our Annual Corn Roast is Sunday August 19. This is a day of food, flying, and fun at our field. Bring

the family, and anything you would like to fly. Open Flying all day – with a brief break for our annual Top Gun competition – where those that choose to fly have 3 minutes of flying to impress the rest of us and walk away with the title of Top Gun 2001.

Our largest event of course is our Midwest Regional Float Fly on September 8 and 9. This event takes a lot of help to run – from impound to flight line to kitchen; setup on Friday and cleanup on Sunday. This event has gotten national coverage in RCModeler several times including

two cover photos, and has been featured in two videos produced by SKS Video. Carl Long is coordinating the event this year. Contact him if you can help out.

Please send me any input you may have for the newsletter. I'll include as many as I can. Note items must be received by the 20th for inclusion in the next issue. Please send via email to GMCardillo@att.net, or by mail to my address on back cover...

# Team Fun Fly For Sale

*Mark Smith*

What a Beautiful day, sunny with a gentle breeze, great day for flying! 20 brave pilots came out to compete in the "World's best fun fly". (That's my opinion anyway). We had some exciting times for pilots and spectators; it is almost as fun to watch as it is to fly in this event. There is something fun about watching a normally calm, cool pilot turn into an adrenaline pumping wild man. When all the cards were dealt and balloons were popped, Dave Shea & Ross Hardy took the advanced trophy home. In the Intermediate class Tim & Gary Bowman walked away with 1<sup>st</sup> place, Gary also won the "Dazzler" grand prize drawing. And Bill Wood aced the Student class. Carl Long and crew worked the kitchen; Jerry Blumenthal & Jack Fleming tallied Scores. A BIG THANKS to everyone that helped this year, without You we couldn't put on these events. I hope everyone had a great time at this year's fun fly. Keep building those fun fly planes for next year!

*(Thanks Mark for running this event.... Sorry I missed it! Ed.)*

Carl Goldberg 40 size Cub—complete and ready to fly. It has a OS .52 4 stroke in it with about 8 tanks of fuel through it & JR XF622 six channel radio with JR receiver and servos. Asking \$550.00. See photo below.

Contact Tim Bowman at:  
248-673-1903 (home)  
810-217-1163 (cell)



## Other Area Events

|            |                         |                                  |  |                  |              |
|------------|-------------------------|----------------------------------|--|------------------|--------------|
| <b>Aug</b> |                         |                                  |  |                  |              |
| 4-5        | Chesaning R/C           | Big Blrd Fly-In                  | IMAA Meet                                  | Michael Freeman  | 517 871-2673 |
| 5          | Pontiac MAC             | 12th Annual Scale Meet           | Scale & Fun Scale                          | Don Hines        | 248 681-2752 |
| 15-16      | Weak Signals            | SAM 40 Meet                      | Old Timer-Wed-Thurs                        | Phil Smith       | 734 429-4707 |
| 18-19      | DAM                     | Giant Scale Air show-Fun Fly     |  | Stan Spiewak     | 313 534-3300 |
| 25-26      | Hobby Stop "Silver Cup" | Pylon Race for Q-40              | In conjunction with the JR Gold Cup Series | Wayne Yeager     | 517 547-4430 |
| 25-26      | Pontiac MAC             | IMAC Pontiac Grand Prix          |  | Don Hines        | 248 681-2752 |
| 25         | Bits & Pieces           | Big Blrd Fly-In...Sat            | Heritage Park-Adrian--80 mono, 60 bipe     | Mike Dilley      | 419 923-4281 |
| 26         | RCCD                    | 1st Annual Open R/C Combat       |  | Don Veres        | 810 778-7362 |
| <b>Sep</b> |                         |                                  |  |                  |              |
| 1-2-3      | Weak Signals            | F5B Team Trials                  | Electric Pylon                             | Kevin Matney     | 734 848-8195 |
| 9          | Chesaning R/C           | Fun Scale Fly-In                 | Any "Looks Like Scale"                     | Michael Freeman  | 517 871-2673 |
| 15-16      | Midland R/C             | Open Fun-Fly                     |  | Rich Erratt      | 517 687-2932 |
| 14-15-16   | Flying Pilgrims         | Fall Phase Out-Big Bird Air Show | IMAA Mini Fest                             | Rich Vukmirovich | 810 468-1360 |

# Skymaster's Events



## Skymasters R/C Club

Join the Skymasters Radio Control Club for an R/C Aircraft event

### **Multi Engine or Multi Wing Saturday August 11, 2001 at the Scripps Road field (see map).**

Any R/C aircraft with either multiple wings, multiple engines or both is eligible. Event flying starts at 10AM, open flying will start at 2PM.

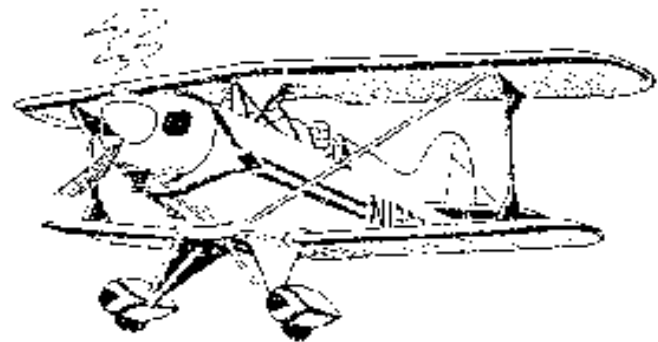
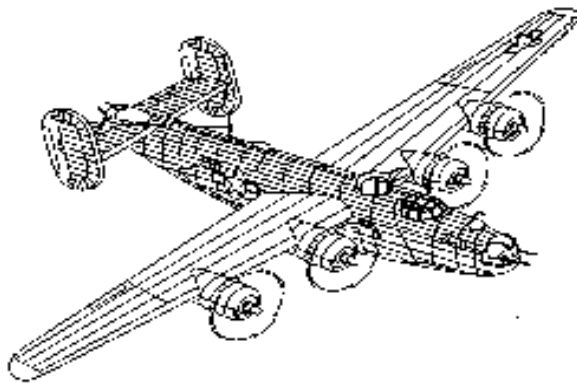

Noise limit - 94Db at ten feet - no exceptions.



- \* Lots of parking.
- \* Refreshments available at events.
- \* Great chance for the public to see this exciting hobby in action.
- \* Toilet located at field.

The Scripps Road flying field is located within the Bald Mountain State Park about five miles north of the Palace of Auburn Hills. All cars need either an annual or day Park permit which is available at the event.

For more information call Gary Walling 248-608-8508

[www.geocities.com/~skymasters](http://www.geocities.com/~skymasters)

# Skymaster's Events



## Skymasters R/C Club

Skymasters Radio Control Club annual club event

### Corn Roast and Top Gun Contest

**Sunday August 19, 2001**

**at the Scripps Road field (see map).**

Club Members, their families and our Scripps Road neighbors please come for our annual Corn Roast and Top Gun event :

\* Free food and drinks available.

\* Flying starts at 10AM.

\* Top Gun contest to find our 1999 Top hot-dog pilot.

\* "Slow Gun" static/flying competition for Great Planes Slow Pokes



Noise limit - 94Db at ten feet - no exceptions.

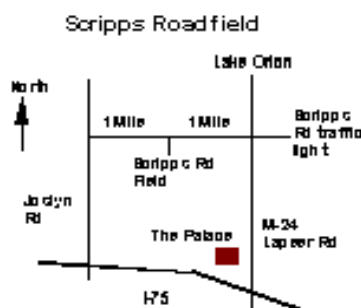

\* Lots of parking.

\* Refreshments available at events.

\* Great chance for the public to see this exciting hobby in action.

\* Toilet located at field.

The Scripps Road flying field is located within the Bald Mountain State Park about five miles north of the Palace of Auburn Hills.

All cars need either an annual or day Park permit which is available at the event.

For more information call Ross Hardy 810-797-4917

[www.geocities.com/~skymasters](http://www.geocities.com/~skymasters)

# Skymaster's Events



## Skymasters R/C Club 10th Annual

Skymasters Radio Control Club annual club event

### Midwest Regional Float Fly

Saturday/Sunday September 8-9, 2001

Island Lake State Park, Brighton, Michigan

Check-In at 8:30; Event flying from 9:30AM-4:00PM each day.

*"The best float flying site I've ever seen!"* — Dave Brown, President AMA



Official Entry Form and  
Additional Information on back.

#### 2001 Super Prize Raffle:

1st Prize: Great Planes Ryan STA  
80", Radio, 4 Stroke Engine  
Ready to Fly!

2nd Prize: Ace Seamaster

Assembled with Thunder Tiger .46 Pro

As seen in  
RCModeler Magazine  
and SKS Videos!

40 acre clear lake  
1,000 feet sand beach  
6 acre lawn / picnic area

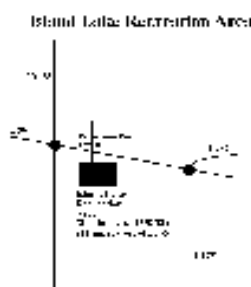

- \* Lots of parking.
- \* Refreshments available at events.
- \* Great chance for the public to see this exciting hobby in action.
- \* Pilot door prizes.

Island Lake Recreation Area is located on the south side of I-96 at Kensington Road. 12 Miles west of I-96 / I-275 intersection or 3 miles east of I-96 / US-23 intersection. All cars need either an annual or day Park permit which is available at the event.

For more information call Carl Long 810-254-0048

[www.geocities.com/~skymasters](http://www.geocities.com/~skymasters)

# Skymaster's Events

## Official Entry Form

Name \_\_\_\_\_ AMA# \_\_\_\_\_ Club \_\_\_\_\_

Street Address \_\_\_\_\_

City \_\_\_\_\_ State \_\_\_\_\_ Zip \_\_\_\_\_ Email \_\_\_\_\_

Primary Aircraft: Model \_\_\_\_\_ Manufacturer \_\_\_\_\_

Primary Frequency: \_\_\_\_\_ Additional Frequencies: \_\_\_\_\_

Phone: Day \_\_\_\_\_ Evening \_\_\_\_\_

Help us plan: "Judged" Contests? Sport \_\_\_\_\_; Standoff \_\_\_\_\_; Scale \_\_\_\_\_

Entry Fee (non refundable unless event is cancelled):

*\$10 if postmarked by 8/31/01; \$20 after. Add \$5 for each 'judged' event.*

Cookout Reservation: \_\_\_\_\_ Adults @ \$12; \_\_\_\_\_ Children @ \$5. (Send \$ with entry)

Mail to: Skymasters, % Carl Long, 8708 Kidley Drive, Sterling Heights, MI 48314

### The Event

Flying from 9:30am to 4:00pm each day. -- Check-in begins at 8:30 each morning.

Aircraft must have been flown & checked for stability and safety before entering this event.

Prizes will be distributed by random drawing, raffle, and special categories as designated by the CD.

The "Super Prize" will be by raffle.

### The "Judged Events" criteria:

You may enter a maximum of 1 model in each class.

Static score = 1/3 and the flight score = 2/3 of the total score.

Static score 0-100 based on "craftsmanship and finish."

Flight score 0-100 based on "smoothness & flight characteristics appropriate the model being flown."

The flight will be judged for 3-4 minutes, including take-off - choose your own maneuvers.

(The landing is not judged but a touch and go during the flight is a definite plus.)

The flight judging will take place during one of your normally scheduled 10 minute "pintimes." All other flight lines will be in operation so other airplanes will be in the air while you are being judged.

In the SPIRIT of this "fun/sport" event the intent is to have a builder - flyer contest. However, if you have a disability which prevents you from flying your model you may have a friend fly it for you. Even though the prizes are large the intent is fun -- this criteria cannot avoid a certain amount of subjectivity, so please enter and fly your model for all to enjoy but remember the intent and that the decision of the judges and the Contest Director are absolutely final.

If you are involved in a team project, please bring it, but don't plan on entering the judging.

To allow us the flexibility to get both the static and flight judging completed, please make every possible effort to attend both days. Winners will be announced at about 2pm on Sunday.

If you win multiple classes you must choose between prizes. The prize you do not choose will go to the 2nd place entry in that class.

*PREVIOUS YEARS WINNERS MAY NOT COMPETE WITH THE SAME MODEL*

**Prizes for judged Contests: Kits from Balsa USA:**

**Sport: 80" Fokker Eindecker E3 Standoff: 80" Citabria Pro;**

**Scale: 1/4 Scale DR-1 Triplane Kit**

### Area Hotels

Check our website for area hotels and discounted prices when available.

## Other Area Events

# Bits & Pieces

R/C Flying Club

Presents:

5th Annual "Hunks & Chunks"

## Big Bird Fly In

*August, 25th, 2001*

*Rain Date Aug. 26th.*

Come fly on our spacious, manicured grass runway located  
in Heritage Parks back 40+ acres. **No Noise Problems Here!**

### LOCATION:

Heritage Park  
M52 Across from the Adrian  
Cinema, just north of  
Downtown Adrian

### REQUIREMENTS:

AMA Membership

### LANDING FEE:

**FREE**

### ACCOMMODATIONS:

Convenient Parking  
Food & Refreshments

### FOR FURTHER INFO CONTACT:

Don Garman  
6572 Baker Hwy.  
Adrian, MI. 49221  
1-517-436-3610

Mike Dilley  
304 Fulton St.  
Lyons, OH, 43533  
1-419-923-4281

### AIRCRAFT:

80" Monoplane  
60" Biplane

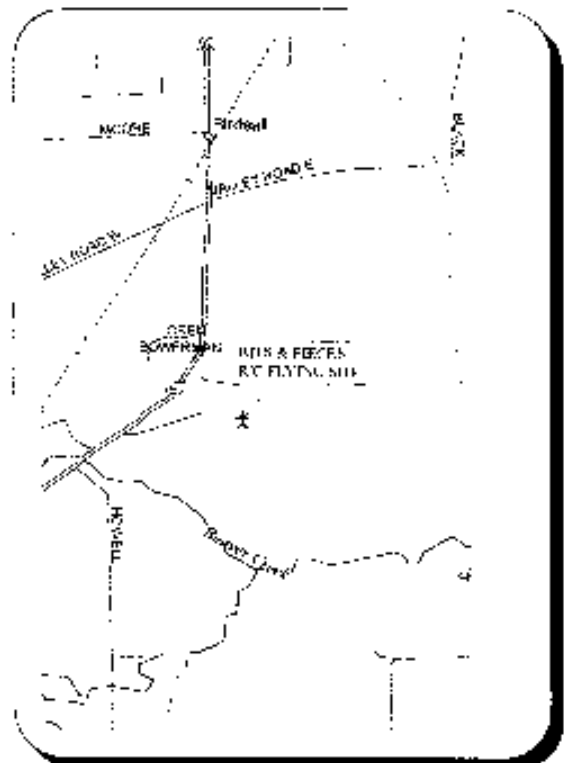



# Skymaster's Photos



Photos from several events in recent path. Photos by Greg Cardillo.

*Kid's Day 2001—Gene Thuringer and Joe Finkelstine teaching one of our visitors (left). Greg Brausa and Dan Devine helping another youngster (right). Weather kept attendance low this year—but all present had fun!!*



*Small Fry and Electric 2001 —A great turnout for this event!! Skymaster Wade Wiley (left) watching the flying. Wade's Miss2 (above) with an unusual hold down. Bob Burns Trainer hauls up a glider for release (right). A view of the pits (below) and a Pico (below right) —Pete Foss and Paul Goelz each own one...*



*Warbirds and Scale 2001—Pete Foss' Chipmunk on landing (below left) and Ross Jones' P-51 lifting its tailwheel for take-off (below right).*





**SKYMASTERS RADIO  
CONTROL CLUB OF  
MICHIGAN**

Greg Cardillo  
2086 Cedar Key Court  
Lake Orion, MI 48360-1800

***www.geocities.com/~skymasters***

**Email: *skymasters@geocities.com***

*Upcoming Events:*

- Aug 1—Student Night  
(every Wed till Labor Day!)*
- Aug 4—Meeting—Scripps Road Field*
- Aug 8—Fish Fry*
- Aug 11—Multi Engine/Multi Wing*
- Aug 19—Corn Roast*
- Sep 8-9—Midwest Regional Float Fly*
- Sep 12—Meeting—Larson Middle School*

**Skymasters  
Infor**

Skymasters field is located within the Bald Mountain State Park on Scripps Road (see map). State Park Permits are required and can be obtained from the Park Headquarters located on Greenshield Road or at club events. Flying is permitted from 10 AM to 8 PM. The noise limit for 2001 is 94 dBA at 10 feet—this noise rule is strictly enforced,

Wednesday evenings during the summer is Student Night and there are usually instructors around all afternoon. Student night is also 'pot luck' buffet night so that

you can fly-n-feed (though not usually at the same time). Students are encouraged on other days and weekends as well. It is a great idea to come on Wednesday, meet the Instructors and arrange for more instruction time together. Our Chief Flight Instructor is Greg Brausa (248) 373-8949.

From June to August, Club meetings are held at the field on the first Saturday of the month at 12 Noon—a great chance to fly and

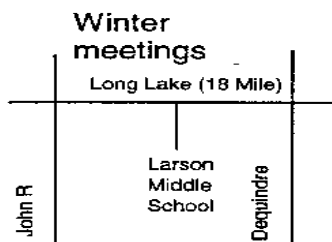
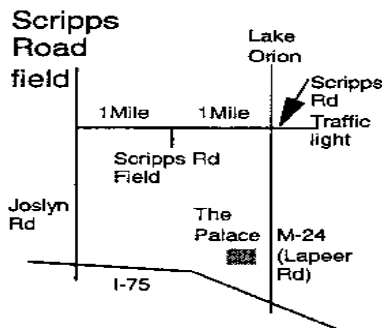

**mation**

gossip too! Winter meetings—September to May—are held at Larson Middle School (on Long Lake just east of John R—see map) on the second and fourth Wednesday of the month at 7:30 PM. Show and Tell, coffee and donuts, and model-speak are the order of the evening. Come along—they are fun,

The Skywriter newsletter is sent to all members, local hobby shops, and other R/C clubs in the area and around the country. Any and all contributions are welcome. Please pass any articles to the Editor. If you know of anyone who may be interested in our hobby (friend, relative, neighbor, colleague or acquaintance), please give them a copy of this newsletter or a copy of an AMA magazine. It may spark their interest and get them into our hobby!