



Academy of Model Aeronautics

Chartered Club #970
10 Year Gold Leader Club

Skywriter

Chet Brady Memorial Float Fly



This happy group of pilots all took home a prize from the Chet Brady Memorial Float Fly thanks to John Hoover at Flightline Hobby and David Wendt.

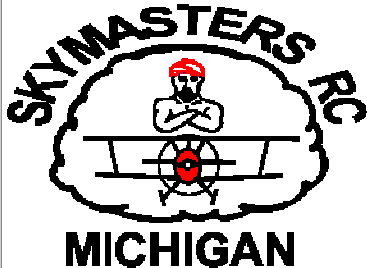

2009 Club Officers & Appointees...

President:	Joe Hass	1142 Brunswick Dr.	Rochester Hills	48309	248-321-7934
Vice Pres:	Paul Zabawa	PO Box 138	Metamora	48455	810-678-3332
Secretary:	David Wendt	4549 Sedona	Clarkston	48348	248-969-8738
Treasurer:	Joe Rubinstein	155 Cayuga	Lake Orion	48362	248-693-4265
Editor:	Pete Foss	562 Tanview Dr.	Oxford	48371	248-236-0676
CFI :	Ron Sokacz	40714 Matlock	Sterling Hts	48310	586-977-1404
State Park:	Bill Stark	1010 E. Clarkston	Lake Orion	48362	248-693-8639
Membership:	Gary Weaks	2512 Red Fox Trail	Troy	48098	248-540-8358

PRESIDENT'S MESSAGE...

When it comes to activities... Who can be busier than the Skymasters?

After the initial "Involvement Day" at the Ranger's Station, another crew went back to finish the roof. Steve Fredericks still has one more project that he will be completing. The Skymasters have made major contributions to the park this year.

Our "Field Opening Party" started 10 days early and continues to be a work in progress because of the volume of projects. Saturday, May 2, found a team led by Steve Fredericks and Mark Smith installing the new benches and work area. Paul Zabawa led a group clearing the approach end of runway 27. The bleachers were installed. Curt Craig and friends repainted the outhouse. Wednesday, May 13, found a group out very early working to repair the roof on the shelter and clear some of the scruff near the road. The roof was finished just as the rain began so work was stopped and everyone made their way to "G's Restaurant for some well deserved nourishment and refreshments. We still have to clear the rest of the scruff and paint the shelter. More on that later. Everything looks great. There is a new gas grill thanks to Dave Wendt and friends and Fred Engelman rebuilt our charcoal grill. Thanks to all who put in so much time and effort.



Float Flying Has Arrived... The Wednesday morning sessions at Stoney Creek have begun. The 7 Lakes and Bald Mountain Float Flies have occurred. Unfortunately both of those fought the winds. Pilots still came out and had a good time. This year we allowed flying at Scripps but only on 2.4GHz as the float fly was going on at Trout Lake. There were very few pilots at either location and no problems. 2.4GHz sure allows a lot more flexibility.



Student Nights Began on Wednesday, May 27.

Come Hungry. Bring someone who wants to learn to fly. These sessions will continue throughout the summer, rain or shine.

AMA Executive Director Jim Cherry will be in town June 4. I have invited the officers of all the local clubs to join us at Ultimate Soccer for a question and answer session with Jim. There are a lot of positive things going on with the AMA, especially dealing with the FAA. Seating is somewhat limited but Skymasters members are welcome to attend. **NOTE! THE TIME OF THE MEETING HAS BEEN CHANGED TO 8:30PM!**

Saturday, June 13 is our annual Electric Fly...Event Director Pete Foss has guaranteed blue skies and light winds (somewhere on the planet), gourmet food and beverages (if you have reservations at the Whitney) and pilots prizes fit for a king (boy am I in trouble). Bring out your electric birds for good time.

Red Bull Air Races June 13 and 14. This time headquartered in Windsor (wonder why?).

(Continued on page 3)

June 14 RCCD will have their annual 2 X 2 event. Two or more motors or wings.

And a chance to fly indoors again... On Thursday, June 18 from 5:30 until 6:30PM. Tickets are \$8.00, \$5.00 for kids 6 to 15. That price includes admission to the Michigan Bucks soccer game that starts at 7 and if enough folks show up discounts on pizza. I hear they are forecasting rain for that afternoon and evening. Honest. Plan on dusting off your indoor projects, getting in some flying and watching a good game too.

Speaking of indoor flying... While we have not worked out all of the details we will be back flying indoors at Ultimate Soccer Arenas in the fall and winter. More to come. This is the best indoor venue anywhere!

There will be an event... The Bald Mountain Park Staff is hosting a reception on Saturday, June 20 at Trout Lake. Float Flying will be permitted. I don't have all the details yet so look for further e mails and more details on the website.

A reminder that there is an AMA membership drive. Have every new member check the box on the application for "Club", write in "Skymasters RC of Michigan" and add Charter #970.

As always the Skymasters are very busy.

See you at the field! Joe Hass



Skymasters R/C Club

We'll Teach you to fly!

Join the Skymasters Radio Control Club for an R/C Aircraft Event

Student Night & Pot Luck Dinners

**Every Wednesday from Memorial Day to Labor Day
Bald Mountain Scripps Road Field**

Rain or Shine! "We always eat, we sometimes fly!"

Student Night:
Instructors available all day (weather permitting)
Open flying – with priority to student flights



Pot Luck Dinner:

For those participating we ask that you:
Bring something for the grill – enough to feed you and your guests
Bring a dish to pass (see note)
Bring your own (non-alcoholic) beverage
We eat at 6pm – rain or shine!

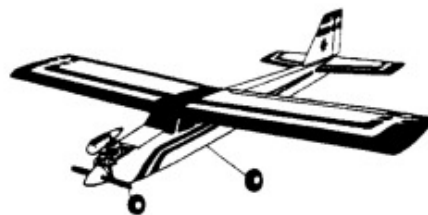

94dBa at 10 feet enforced.

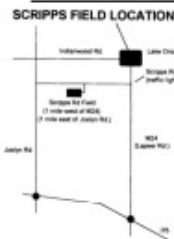

•Dish to pass: Don't know what to bring?
Each week a board will be up listing supplies needed – from plates to condiments, charcoal, etc. Pick one of the needed items to bring instead!
The potluck is sustained by those participating with no expense to club.

Flying field is located within the Bald mountain recreation Area, about 5 miles north of the Palace of Auburn Hills on Scripps Road between Lapeer Rd (M24) and Joslyn Rd.
All cars need annual/daily State Park sticker – available at event.

For more information call Charles and Dairdre McGlothlin 248-364- 4194

Visit our website at www.skymasters.org



Keith Shaw Visit

Wednesday April 22 2009 Larson Middle School

Attendance: 46 people in attendance.

Guest Speaker: Keith Shaw on receiver and transmitter batteries. The first NiCad batteries were produced in the 1940s in Germany. Keith said they worked pretty well and he was able to get them from army surplus stores. Keith also showed us a vintage 1960's battery that was capable of exploding if it was accidentally charged backwards. Keith explained how NiCads store power between two plates. One plate is made of nickel and the other of cadmium. There is a chemical reaction between the two plates storing and releasing energy. Unfortunately Cadmium is not environmentally friendly.

Keith explained the term impedance. High impedance means it is difficult to get energy in or out of the battery. Keith showed us typical capacity discharge curves. Keith also dispelled the fallacy that NiCad cells have capacity memory. This is not true. This is not a viable reason to move away from NiCads.

What makes a NiCad go bad? The reactive jelly and the plates themselves tend to deteriorate. The electrolytic jelly can crystallize and grow away from the plates. A good indicator of a NiCad going bad is the self discharge rate. If you notice a NiCad losing its charge quickly, then it's a good indicator that the battery is starting to go bad. Another indication of a NiCad going bad is the negative wire corroding. The positive wire will also get brittle but the negative side wire will go first. Another cause of NiCad failure is crashing. Many times a crash will dent the battery and it goes unnoticed because of the plastic casing. If a NiCad battery is dented chances are very good the internal welds in the battery have been damaged and the battery is on a short boat ride to failure.

Fast charging can and will damage packs if the batteries have not been used for several days. The self discharge rate can vary for each cell of the pack. Fast charging has a tendency to ruin the best cells in the pack. The cells that have retained the most charge will be the first to cook. When the pack is well balanced this is not an issue. However, NiCad batteries self discharge and it is rare that they are well balanced unless they were slow charged within the last 24 hours.

How do I make my NiCad battery packs last a long time? Slow charging is best. It is ok to fast charge at multi day flying events because the packs do not get a chance to become unbalanced. Cycling the battery pack twice a year is a good idea. A simple way to check for a bad pack is by fully cycling a pack and then letting it sit for a couple of weeks. After the rest time take notice of how much energy it takes to recharge the pack. If the pack was nearly dead then the pack needs to be replaced.

A good way to check your battery pack between flights is to take a 10 ohm resistor in a circuit from the battery pack to a standard volt meter. The resistor will put some load on the battery and you will get a very accurate voltage reading. *(Or use an expanded scale meter or digital meter with a built in load).*

A great replacement battery for our radios is a LiPo pack TrueRC sells a 3 cell 2800 mAh pack that works great in an RC radio. The flight time between charging will jump to about 2.5 hours. That's a lot of flying.

Keith recommends isolation circuits for the servos and receivers on large airplanes with high torque digital servos. The large servos have a tendency to cause high power draw spikes which robs the newer 2.4 GHz receiver of necessary operating voltage. He also recommends at least 22 gage wire for the entire power circuit. A large battery pack will do you no good if the wire is not able to deliver the current.

Show and tell:

Terry Overton: CAP 232 ARF with a Saito 100

Chris Hass: SAPAC Yak 54 receiver ready and Raptor 50se O.S hyper 50 A123 receiver battery

Scott Abbot: ParkZone Typhoon he uses to practice hovering. The plane has a great power to weight ratio and repairs easily.

Neal Krohn showed us a home made motor. Neal uses this motor to demonstrate how motors work to third grade students.

Spring Float Flys

Once again the weather was cold and wind was gusting to 25 mph. Did that stop Skymasters from showing up and getting planes into the air? Not a chance. A few Holly Cloud Busters even made it to the event. Planes flew and landed without a single crash. Wad Wiley even got a chance to tear up the lake with a gas powered RC speed boat. Food was served and prizes were given to lucky pilots. A big thanks goes out to John Hoover at Flightline Hobbies for donating the prizes. - David Wendt

The story at the Trout Lake Float Fly was more of the same! Since the wind was a bit less bad, quite a few pilots flew successfully. Thanks to Joe Rubenstein everybody had a prize and a burger or brat or two. Special thanks to Wade Wiley for providing the kayak for retrieval. - Pete Foss





Skymasters R/C Club

We'll Teach you to fly!

Join the Skymasters Radio Control Club for an R/C Aircraft Event

Electric Fly!

Saturday June 13, 2009

Bald Mountain Scripps Road Field

Event Flying starts at 10am



**Public
Welcome!**

Electric Powered Aircraft Only!

**From slow flying 'park flyers' to full aerobatics and scale
Come see what electric power can do today!**

Flying open to AMA members. 94dBa at 10 feet enforced.

SCRIPPS FIELD LOCATION

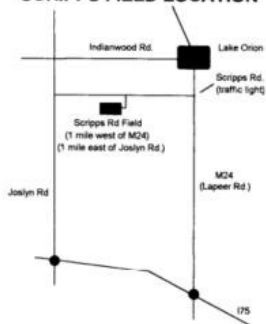

- Lots of Parking
- Refreshments available at event
- Toilet located at field
- Great chance to see this exciting hobby!

No Landing Fee
Pilots Prizes!

Flying field is located within the Bald mountain recreation Area, about 5 miles north of the Palace of Auburn Hills on Scripps Road between Lapeer Rd (M24) and Joslyn Rd.

All cars need annual/daily State Park sticker – available at event.

For more information call Pete Foss 248-236-0676

Visit our website at www.skymasters.org



Skymasters R/C Club

We'll Teach you to fly!

Join the Skymasters Radio Control Club for an R/C Aircraft Event

Harold 'Big H' Maseles Warbirds and Scale

Sunday July 19, 2009

Bald Mountain Scripps Road Field

Event Flying starts at 10am

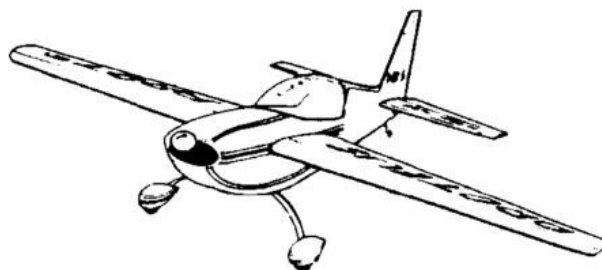
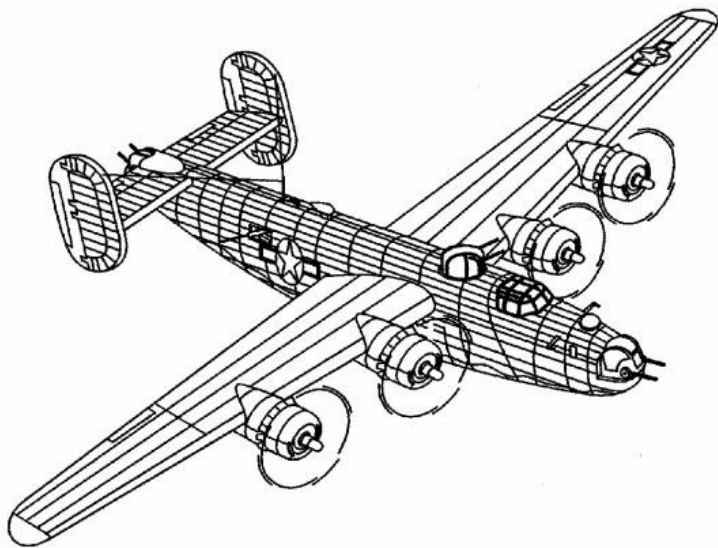

**Public
Welcome!**

Flying open to AMA members. 94dBa at 10 feet enforced.

SCRIPPS FIELD LOCATION

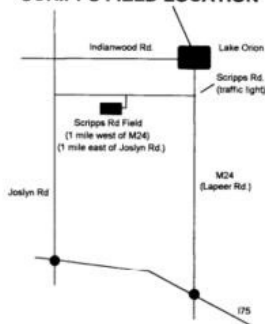

- Lots of Parking
- Refreshments available at event
- Toilet located at field
- Great chance to see this exciting hobby!

No Landing Fee
Pilots Prizes!

Flying field is located within the Bald mountain recreation Area, about 5 miles north of the Palace of Auburn Hills on Scripps Road between Lapeer Rd (M24) and Joslyn Rd.

All cars need annual/daily State Park sticker – available at event.

For more information call Joe Finkelstine 248-877-0086

Visit our website at www.skymasters.org

UPCOMING SKYMASTERS EVENTS

June 2009

Stony Creek Float Flying - Wednesdays Thru October**Stony Creek Metropark - 9:00 AM**

Every Wednesday the weather allows. Come fly off water at Stony Creek Metro Park on Wednesday mornings. Flying from Winter Cove. Contact Jim Held for more info and to get on mailing list for cancellations.

Student Night and Potluck - Wednesdays Thru Summer**Scripps Road Field, Lake Orion - 10:00 AM**

Every Wednesday thru Labor Day! Instructors available all day (flying dependent on weather conditions) - Potluck Dinner at 6pm Regardless of the weather! Bring meat (or other) for the grill, a dish to pass, and non-alcoholic beverage. "We always eat, we sometimes fly!"

Skymasters Summer Meeting - Wednesday, June 10, 2009**Scripps Road Field. Lake Orion - 8:00 PM**

Summer meetings are short - following student night!

Electric Fly In - Saturday, June 13, 2009**Scripps Road Field, Lake Orion - 10:00 AM**

Come see what electric airplanes can do! The advances in technology make anything possible with electric. Any size electric powered airplanes ONLY.

Skymasters Summer Meeting - Wednesday, July 8, 2009**Scripps Road Field. Lake Orion - 8:00 PM**

Summer meetings are short - following student night!

Warbirds and Scale - Sunday, July 19, 2009**Scripps Road Field, Lake Orion - 10:00 AM**

From P51's to Tiger Moths, Cessnas to Tomcats. There should be lots of variety in the air and on the ground. Come see the old Warbirds, Military and Civilian scale planes.

Skymasters Summer Meeting - Wednesday, August 12, 2009**Scripps Road Field. Lake Orion - 8:00 PM**

Summer meetings are short - following student night!

Corn Roast and Top Gun - Sunday, August 23, 2009**Scripps Road Field, Lake Orion - 10:00 AM**

This is the club event of the year with our annual 'Top Gun' pilot competition. A field full of aircraft and some great flying - a great day out for all club members, their families, and our neighbors.

Camper For Sale

Skymasters member Fred Johnson is selling his Mallard Travel Trailer .The trailer is 24 feet long with a hitch, awning, tanks, etc. The complete price of the trailer is \$4,000.00.

Please contact: Debby & Gary Schulte 248-661-0321



Radio Control Club of Detroit
www.rccd.org



2x2 Rally

(2 or more wings; 2 or more engines)

Date: June 14, 2009
Times: Pilots' Meeting at 9:30 AM
Flying Starts at 10:00 AM
Location: RCCD Flying Field in Wetzel State Park (see map)
Format: Fun Fly - No competition
Sanction Number - 09-0961
CD: Emie Varilone - CD
586-566-8237
Skip Gizowski
734-981-2079 co-CD
Peter VanHeusden
248-515-1071

Put the lawn mower away, turn off the TV, get off the sofa, & join us for a day of fun flying.

Aircraft are limited to multi-wings and/or multi-engines. Power may be gas, nitro, or electric.

We know that you have one of these lurking in your basement, so bring it out into the bright sunshine and gentle winds for a pleasant day of flying.

Who knows, you may win a great prize (well alright, maybe an OK prize)

Flying at the 2x2 Rally is open to any current AMA member.

In addition, there will be a draw for spectators to try their hand at R/C flying (Weather permitting). Don't worry, we have a good system to keep you & our plane safe!

- Ample parking and bleacher seating.
- Refreshments available at very reasonable prices.
- Parking donation: \$3.00
- Landing Fee (for 2x2 pilots): \$5

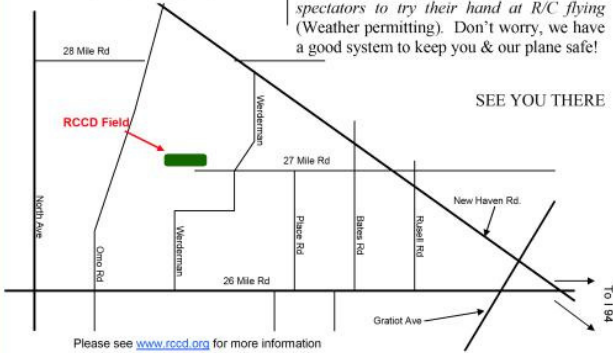

Please see www.rccd.org for more information

**Balsa Butchers
Keith Shaw Birthday Party
Electric Fly-In
June 6-7, 2009**

The Balsa Butchers will once again be hosting the "Keith Shaw Birthday Party Electric Fly-In" at their field near Coldwater, MI.

Flying: 9AM-5PM Sat and 9AM-3PM Sun.

Directions: Quincy is approximately 4.5 miles east of I-69. Clizbe Road is approximately 1.6 miles east of Quincy. The Flying site is approximately 1.5 miles south of US-12 on the west side of Clizbe Road.

Dave Grife
Phone: (517) 279-8445
grifed@yahoo.com

Mid-America Electric Flies 2009
At the 7 Mile Road MRCS Field
2nd Year at the New Field
Location!

AMA Sanctioned
Saturday, July 11 & Sunday, July 12, 2009
Hosted by the:

Ann Arbor Falcons and Electric Flyers Only

Site Provided by the:

Midwest R/C Society

Contest Directors are:

Ken Myers phone (248) 669-8124 or
KMyersEFO@aol.com - <http://homepage.mac.com/kmyersef/>
Keith Shaw (734) 973-6309

Flying both days is at the Midwest R/C Society Flying Field - 7 Mile Rd., Northville Twp., MI
(see map on map/hotels flyer)

Registration: 9 A.M. both days
Flying from 10 A.M. to 5 P.M. Sat. & 10 A.M. to 3 P.M. Sunday

Channels 00 through 60, the six 27MHz frequencies, & eight 53MHz frequencies, will be in use. Flying on five 49 MHz frequencies may be accommodated on request - Narrowband receivers are recommended for flying on Channels 00 - 60 - Very Wideband 27, 49, & 53 MHz, receivers may be accommodated on request - 2.4Ghz controlled at impound

Pilot Entry Fee \$15 a day or \$25 both days - - - Parking Donation Requested from Spectators

Saturday's Events
Best Scale
Most Beautiful
Best Ducted Fan
Best Sport Plane
CD's Choice

Sunday's Events
Best Scale
Most Beautiful
Best Mini-Electric
Best Multi-motor
CD's Choice

Planes Must Fly To Be Considered for Any Award

Open Flying Possible on Friday
Night Flying Possible, Weather Permitting, Friday & Saturday Nights
Refreshments will be available at the field both days.

Potluck picnic at the field on Saturday evening.

Come and join us for two days of fun and relaxed electric flying.

Come, Look, Listen, Learn - Fly Electric - Fly the Future!
Saturday's & Sunday's Awards:
Plaques for 1st in each category
Merchandise drawing for ALL entrants

FLYIN' HIGH WITH THE
MI BUCKS



FLY TIME*: 5:30PM TO 6:30PM
GAME TIME: 7:30PM

DATE: JUNE 18, 2009

PURCHASE TICKETS TO THE MI BUCKS
SOCCER GAME AND GET FREE FLY TIME
BEFORE. STAY AND WATCH THE HALFTIME
SKYMASTERS DEMONSTRATION
TO ORDER TICKETS
CALL MELANIE AT (248) 648-7000

TICKETS ARE ONLY :
\$8 FOR ADULTS
\$5 FOR CHILDREN/STUDENTS 6-15
KIDS 5 & UNDER FREE
FOR EVERY TEN TICKETS PURCHASED
RECEIVE A COUPON TO BUY A LARGE ONE
TOPPING PIZZA FOR ONLY \$8



ULTIMATE SOCCER ARENAS
867 SOUTH BLVD.
PONTIAC, MI 48341
(248) 648-7000
WWW.ULTIMATESOCCERARENAS.COM





SKYMASTERS RADIO CONTROL CLUB OF MICHIGAN

Pete Foss
562 Tanview Dr.
Oxford, MI. 48371

Web site: www.skymasters.org
Email: newsletter@skymasters.org



PHOTOGRAPHY by
David Wendt and Pete Foss



Skymasters Information.....

Skymasters field is located within the Bald Mountain State Park on Scripps Road (see map). State Park Permits are required and can be obtained from the Park Headquarters located on Greenshield Road or at club events. Flying is permitted from 10 AM to 8 PM. The noise limit is 94 dBa at 10 feet—this noise rule is strictly enforced.

In the summer, Wednesday evenings are Student Nights and there are usually instruc-

tors around all night is also a

SCRIPPS ROAD FIELD

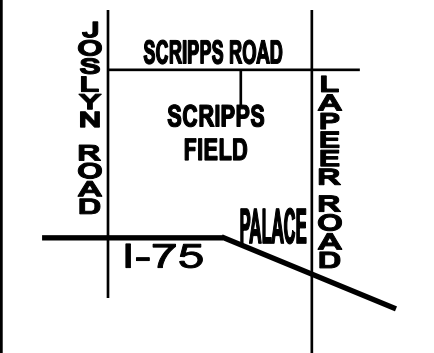

WINTER MEETINGS

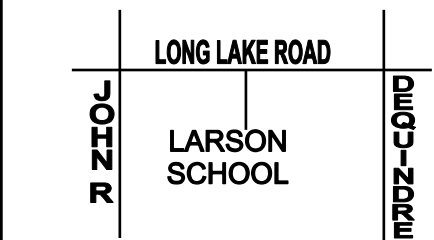

Student pot luck buffet, bring something for the grill & a dish to pass. Meet the Instructors and arrange for more instruction time together on other days. Our Chief Flight Instructor is Ron Sokacz (586) 977-1404.

From June to August, Club meetings are held at the field, on the second Wednesday of

the month at 8 PM. A great chance to fly and socialize. Winter meetings—September to May—are held at Larson Middle School (on Long Lake just east of John R—see map) on the second and fourth Wednesday of the month at 7:00 PM. Bring a model for Show and Tell, enjoy coffee with donuts and listen to the speaker of the evening.

The Skywriter newsletter is sent to members, local hobby shops, and other R/C clubs in the area and around the country. All contributions are welcome. Please send articles to the Editor. If you know of anyone who may be interested in R/C Aviation, please give them a copy of this newsletter or a copy of an AMA magazine. It may spark their interest!