



Academy of Model Aeronautics

Chartered Club #970
10 Year Gold Leader Club

Skywriter

Electric Meet 2009



Jim Satawa was one of the 46 pilots who flew at the electric meet. Here he gets ready to launch a powered sailplane.

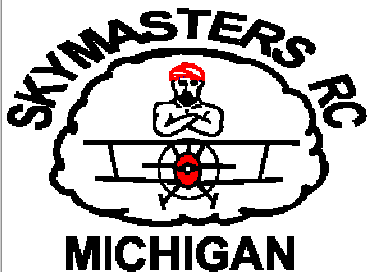

2009 Club Officers & Appointees...

President:	Joe Hass	1142 Brunswick Dr.	Rochester Hills	48309	248-321-7934
Vice Pres:	Paul Zabawa	PO Box 138	Metamora	48455	810-678-3332
Secretary:	David Wendt	4549 Sedona	Clarkston	48348	248-969-8738
Treasurer:	Joe Rubinstein	155 Cayuga	Lake Orion	48362	248-693-4265
Editor:	Pete Foss	562 Tanview Dr.	Oxford	48371	248-236-0676
CFI :	Ron Sokacz	40714 Matlock	Sterling Hts	48310	586-977-1404
State Park:	Bill Stark	1010 E. Clarkston	Lake Orion	48362	248-693-8639
Membership:	Gary Weaks	2512 Red Fox Trail	Troy	48098	248-540-8358

PRESIDENT'S MESSAGE...

A great way to start the month...AMA Executive Director Jim Cherry was planning to be in town on personal business the evening of June 4. He gave us a call to see if he could take advantage of the situation to also meet with local clubs. A call went out to our friends at Ultimate Soccer to see if the meeting room was available. It was, but only later in the evening because of a high school graduation. Using our databases, electronic invitations went out to over 180 clubs. The response was fantastic. Over 25 folks, some driving over 100 miles, came together to hear Jim give us the first public presentation of the work going on with the FAA and Unmanned Aerial Vehicles (UAV). Jim also went over the new AMA membership drive. We were even honored to have 2 Hall of Fame members present, Pete Waters and Keith Shaw.

After the presentation we adjourned to one of the soccer fields. To say that Mr. Cherry was impressed with the facility would be an understatement. I brought along a variety of indoor aircraft. Anyone interested got some stick time, including Jim. One of Jim's comments was "I can't believe you guys get to fly in here once a week all winter long. Pictures just don't do this place justice". Jim made sure to give George Derderian his personal thanks for allowing all of us the opportunity to fly in this great site.

Speaking of flying indoors...Remember that on Thursday, June 18 we will have a chance to again fly indoors with a lot of great twists. The cost will be \$8.00. Flying will last 1 hour, from 5:30PM to 6:30PM. But this price will include admission to the Michigan Bucks Soccer game that starts at 7PM. If enough folks show up there will also be discounts available for pizza. This is a great way to enjoy a flying change of pace and an interesting sport. Please take a look at the flyer elsewhere in the newsletter for all the details.

Electric Fly 2009...Hats off to Pete Foss for another wonderful event. Dodging any real rain and enjoying virtually calm winds there were crowds at all the flight stations all day long. Thanks to the generosity of many suppliers there were great Pilot's Prizes too.

Our next Skymasters event is Warbirds and Scale on Sunday, July 19. If you thought "In the Bones" was great over the winter wait until you see all the finished projects in the air. Always a good time.

There was a new P-51 at the Electric event...14 year old National Champion Danny Craig lost his Miss America P-51 during practice last year. He brought out his new Miss America, this time converted to electric power. It flew very well. Danny plans to go back to the NATS again this year. The airplane, and the way Danny flies it, sure turned some heads.



Totally Personal...As I write this son Chris has finished round 2 of the Extreme Flight Championships (XFC) in Muncie, IN. No second round scores yet. He finished 13th (out of 17) at the end of round one. This is his first XFC. He is flying against the best of the best, factory pilots and professionals. We are very proud of him.

Chris needed to get a glider so he could compete at the glider nationals later this summer. The problem was that the glider was in Champaign, IL. Well, this weekend it got a little closer as the owner was going to be in Ashtabula, OH (just east of Cleveland) at the Unlimited R/C Races. I needed a check out in the Cardinal 177RG and the races were at the Ashtabula Airport. There seemed to be a plan here. One hour over Lake Erie and we were there. The racers were simply unbelievable. Peter Goldsmith of Horizon was in first place at 238MPH. Each race consumes 1 gallon of fuel. The flight back (with glider in tow so to speak) took us over downtown Detroit to see the Red Bull Racers practicing over the river.

Things are good. See you at the field.
Joe Hass

FLYIN' HIGH WITH THE
MI BUCKS



FLY TIME* : 5:30PM TO 6:30PM
GAME TIME: 7:30PM

DATE: JUNE 18, 2009

PURCHASE TICKETS TO THE MI BUCKS
SOCCER GAME AND GET FREE FLY TIME
BEFORE. STAY AND WATCH THE HALFTIME
SKYMASTERS DEMONSTRATION

TO ORDER TICKETS
CALL MELANIE AT (248) 648-7000

TICKETS ARE ONLY :

\$8 FOR ADULTS

\$5 FOR CHILDREN/STUDENTS 6-15

KIDS 5 & UNDER FREE

*FOR EVERY TEN TICKETS PURCHASED
RECEIVE A COUPON TO BUY A LARGE ONE
TOPPING PIZZA FOR ONLY \$8*



ULTIMATE SOCCER ARENAS
867 SOUTH BLVD.
PONTIAC, MI 48341
(248) 648-7000
WWW.ULTIMATESOCCERARENAS.COM

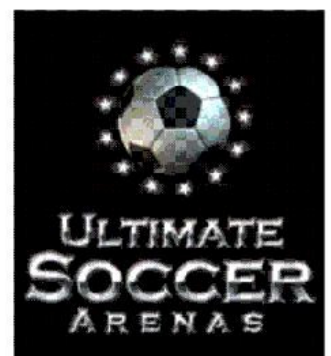

I woke up yesterday, June 13th to drizzle but by 10 AM the rain had stopped and the wind never came up. Fantastic weather for an event. We didn't even have to deal with bright sunshine. This event wouldn't be possible without a lot of help from other club members. First Joe Hass was incredible as usual bringing in prizes from Scott Pavlock and Castle Creations, Fancy Foam, Sig, Hobby-Lobby and Cermak. In addition, we had prizes from Jason (www.flyairhobbyrc.com) and club members Ross Jones (<http://www.airlandseahobby.com/>), Terry Overton and Jim Satawa. Jason and Ross both also setup onsite for shoppers. I'd also like to thank Neil Krohn for shopping for the food, Greg Cardillo and Carolynn Foss for setting up, cooking, teardown, etc. etc. etc. With 46 pilots plus spectators we put away 40 hamburgers, 20 brats and 40 hot dogs! We are an eating club after all! Thanks to everyone who came and we'll see you next year....Pete



Electric Meet 2009



AMA Executive Director Jim Cherry Visit

As Joe mentioned in his President's letter, Jim Cherry, the Executive Director of AMA was in Detroit on personal business the evening of June 4th. While he was in town, he asked us if we could put together a meeting with representatives from local clubs to discuss the ongoing discussions between the FAA, Homeland Security, AMA and the model airplane and unmanned aerial vehicle (UAV) industries. After meeting with Jim at Ultimate Soccer, we went into one of the fields for a little flying.

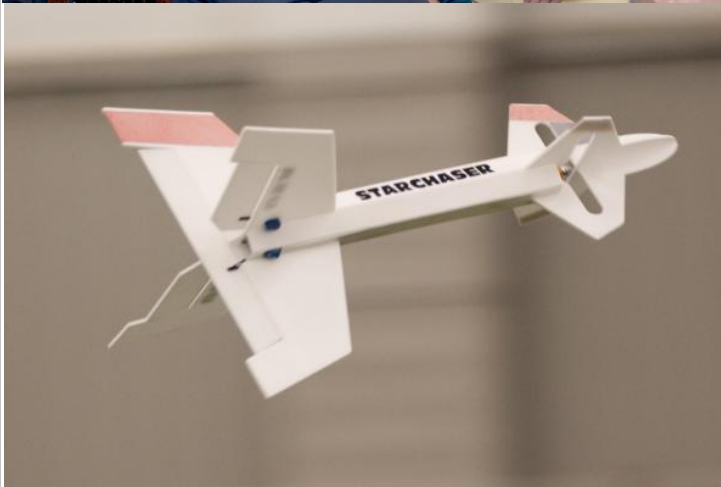



Skymasters R/C Club

We'll Teach you to fly!

Join the Skymasters Radio Control Club for an R/C Aircraft Event

Harold 'Big H' Maseles Warbirds and Scale

Sunday July 19, 2009

Bald Mountain Scripps Road Field

Event Flying starts at 10am

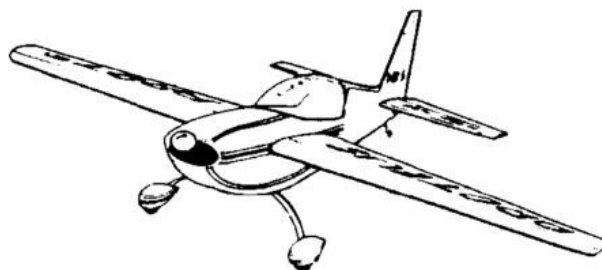
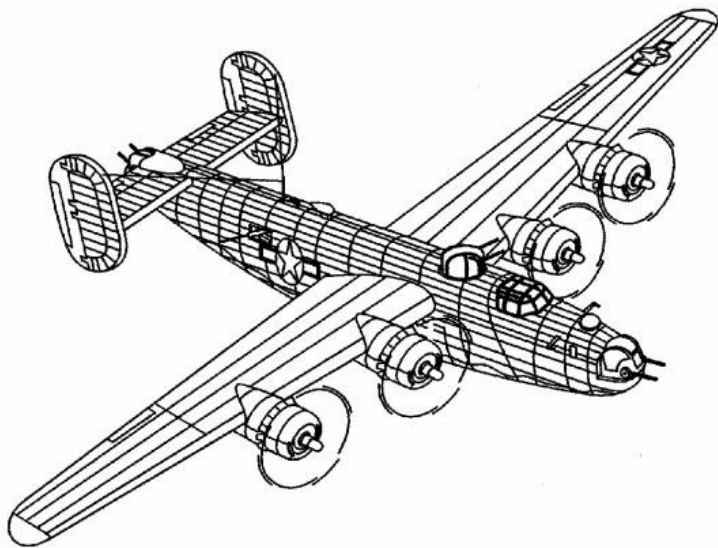

**Public
Welcome!**

Flying open to AMA members. 94dBa at 10 feet enforced.

SCRIPPS FIELD LOCATION

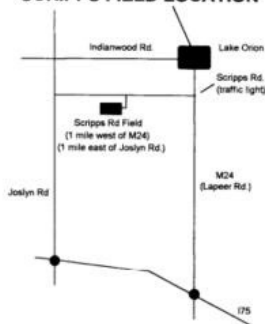

- Lots of Parking
- Refreshments available at event
- Toilet located at field
- Great chance to see this exciting hobby!

No Landing Fee
Pilots Prizes!

Flying field is located within the Bald mountain recreation Area, about 5 miles north of the Palace of Auburn Hills on Scripps Road between Lapeer Rd (M24) and Joslyn Rd.

All cars need annual/daily State Park sticker – available at event.

For more information call Joe Finkelstine 248-877-0086

Visit our website at www.skymasters.org

Stony Creek Float Flying - Wednesdays Thru October**Stony Creek Metropark - 9:00 AM**

Every Wednesday the weather allows. Come fly off water at Stony Creek Metro Park on Wednesday mornings. Flying from Winter Cove. Contact Jim Held for more info and to get on mailing list for cancellations.

[Starts May 6th - check here for weekly status and any cancellation notices due to weather.](#)

Student Night and Potluck - Wednesdays Thru Summer**Scripps Road Field, Lake Orion - 10:00 AM**

Every Wednesday thru Labor Day! Instructors available all day (flying dependent on weather conditions) - Potluck Dinner at 6pm Regardless of the weather! Bring meat (or other) for the grill, a dish to pass, and non-alcoholic beverage. "We always eat, we sometimes fly!"

[Starts the Wednesday after Memorial Day!](#)

Skymasters Summer Meeting - Wednesday, July 8, 2009**Scripps Road Field. Lake Orion - 8:00 PM**

Summer meetings are short - following student night!

Warbirds and Scale - Sunday, July 19, 2009**Scripps Road Field, Lake Orion - 10:00 AM**

From P51's to Tiger Moths, Cessna's to Tomcats. There should be lots of variety in the air and on the ground. Come see the old Warbirds, Military and Civilian scale planes.

Skymasters Summer Meeting - Wednesday, August 12, 2009**Scripps Road Field. Lake Orion - 8:00 PM**

Summer meetings are short - following student night!

Corn Roast and Top Gun - Sunday, August 23, 2009**Scripps Road Field, Lake Orion - 10:00 AM**

This is the club event of the year with our annual 'Top Gun' pilot competition. A field full of aircraft and some great flying - a great day out for all club members, their families, and our neighbors.

Midwest Regional Float Fly**Saturday/Sunday, September 12-13, 2009****Island Lake State Park, Brighton - 9:30 AM**

This is the big one! Float flyers from all over the Midwest bring all sizes, shapes, and color of aircraft imaginable and fly them for two days solid. A blast! Flying starts at 9:30 AM both days!

Mid-America Electric Flies 2009

At the 7 Mile Road MRCS Field

2nd Year at the New Field

Location!

AMA Sanctioned

Saturday, July 11 & Sunday, July 12, 2009

Hosted by the:

Ann Arbor Falcons and Electric Flyers Only

Site Provided by the:

Midwest R/C Society

Contest Directors are:

Ken Myers phone (248) 669-8124 or

KMyersEFO@aol.com – <http://homepage.mac.com/kmyersefo/>

Keith Shaw (734) 973-6309

Flying both days is at the Midwest R/C Society Flying Field - 7 Mile Rd., Northville Twp., MI
(see map on map/hotels flyer)

Registration: 9 A.M. both days

Flying from 10 A.M. to 5 P.M. Sat. & 10 A.M. to 3 P.M. Sunday

Channels 00 through 60, the six 27Mhz frequencies, & eight 53MHz frequencies, will be in use. Flying on five 49 MHz frequencies may be accommodated on request - Narrowband receivers are recommended for flying on Channels 00 - 60 - Very Wideband 27, 49, & 53 MHz, receivers may be accommodated on request – 2.4Ghz controlled at impound

Pilot Entry Fee \$15 a day or \$25 both days - - - - Parking Donation Requested from Spectators

Saturday's Events

Best Scale
Most Beautiful
Best Ducted Fan
Best Sport Plane
CD's Choice

Sunday's Events

Best Scale
Most Beautiful
Best Mini-Electric
Best Multi-motor
CD's Choice

Planes Must Fly To Be Considered for Any Award

Open Flying Possible on Friday

Night Flying Possible, Weather Permitting, Friday & Saturday Nights

Refreshments will be available at the field both days.

Potluck picnic at the field on Saturday evening.

Come and join us for two days of fun and relaxed electric flying.

Come, Look, Listen, Learn - Fly Electric - Fly the Future!

Saturday's & Sunday's Awards:

Plaques for 1st in each category

Merchandise drawing for ALL entrants



SKYMASTERS RADIO CONTROL CLUB OF MICHIGAN

Pete Foss
562 Tanview Dr.
Oxford, MI. 48371

Web site: www.skymasters.org
Email: newsletter@skymasters.org



PHOTOGRAPHY by
Greg Cardillo and Jim Maughan



Skymasters Information.....

Skymasters field is located within the Bald Mountain State Park on Scripps Road (see map). State Park Permits are required and can be obtained from the Park Headquarters located on Greenshield Road or at club events. Flying is permitted from 10 AM to 8 PM. The noise limit is 94 dBa at 10 feet—this noise rule is strictly enforced.

In the summer, Wednesday evenings are Student Nights and there are usually instruc-

tors around all night is also a

SCRIPPS ROAD FIELD

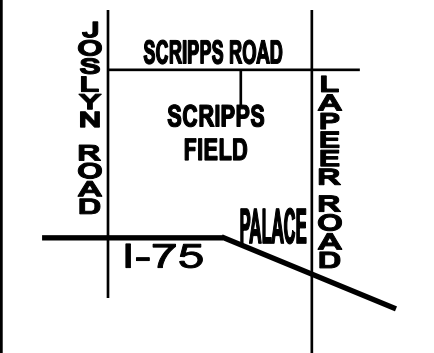

WINTER MEETINGS

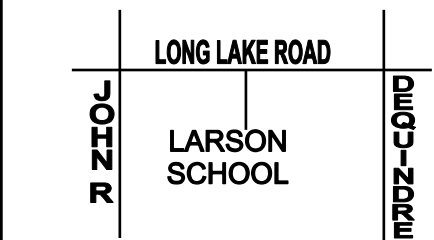

Student pot luck buffet, bring something for the grill & a dish to pass. Meet the Instructors and arrange for more instruction time together on other days. Our Chief Flight Instructor is Ron Sokacz (586) 977-1404.

From June to August, Club meetings are held at the field, on the second Wednesday of

the month at 8 PM. A great chance to fly and socialize. Winter meetings—September to May—are held at Larson Middle School (on Long Lake just east of John R—see map) on the second and fourth Wednesday of the month at 7:00 PM. Bring a model for Show and Tell, enjoy coffee with donuts and listen to the speaker of the evening.

The Skywriter newsletter is sent to members, local hobby shops, and other R/C clubs in the area and around the country. All contributions are welcome. Please send articles to the Editor. If you know of anyone who may be interested in R/C Aviation, please give them a copy of this newsletter or a copy of an AMA magazine. It may spark their interest!